

Penstocks

Sizes from DN100 & above

- Lightweight range of wall mounted penstocks
- Easy and quick installation – no need for grout between frame and wall
- Corrosion resistant
- Robust and rigid construction
- UV stable
- Minimal maintenance required
- Manufactured to DIN 19569-4 (class 5)

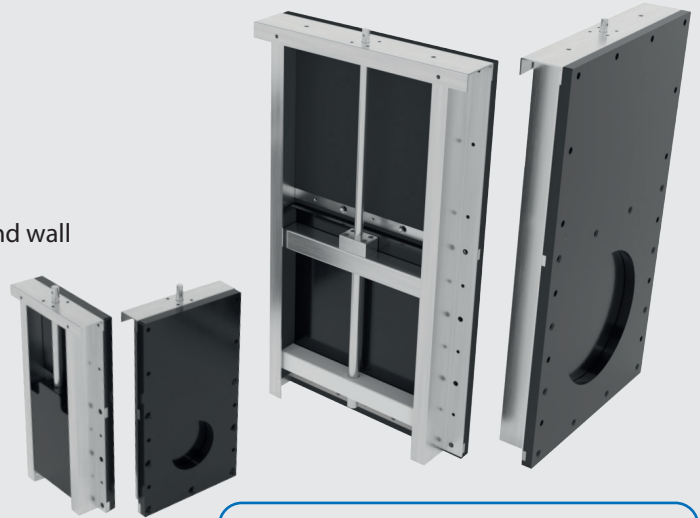

Larger sizes available on request

HDPE Penstocks from Fernco provide a high strength, easy to install solution to control the flow of water and wastewater.

Penstocks, in their basic form, are permanent water gates that control the flow of water from one area to the next, which can be manually adjusted to produce the desired flow. They are often used on Waterways, Power Plants, Industrial Effluent Plants, Hydro Power, Sewerage/Wastewater Treatment Plants, Drainage and Flood Control.

With a core range manufactured from HDPE (High Density Polyethylene), Fernco's range offers considerable benefits over other materials including:

1. Operational

The range is considerably lighter than alternatives, resulting in easier installation with no grout required between frame and wall.

2. Maintenance

The product mechanism is self lubricating between the frame and the door resulting in a longer life product. The range has leakage rates that are better than those required in DIN 19569-4 class 5.

All Fernco Penstocks come with a BS Cap supplied.



Product Specification

Front Side

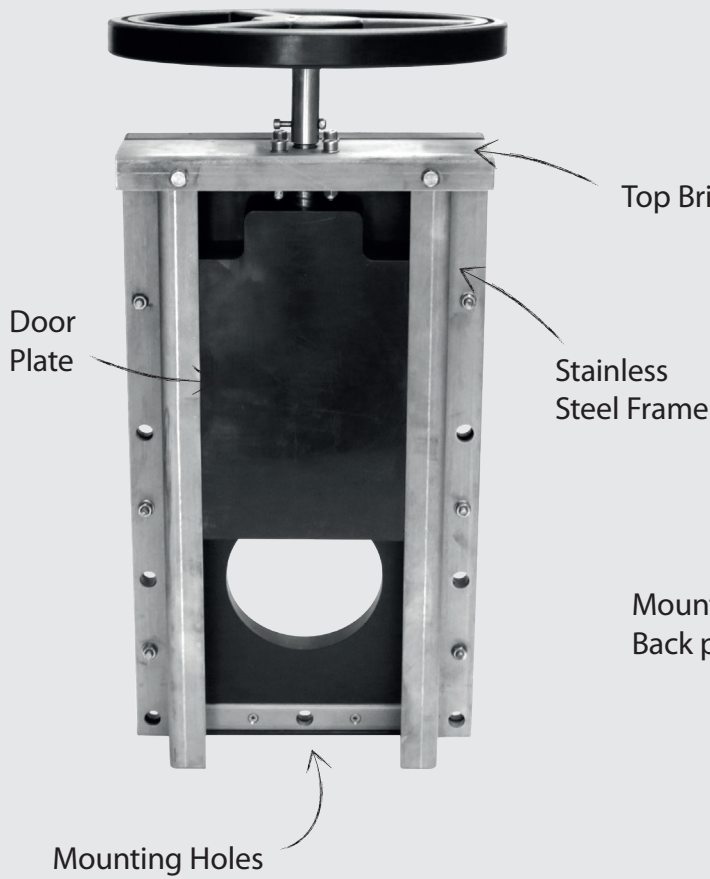

BS CAP

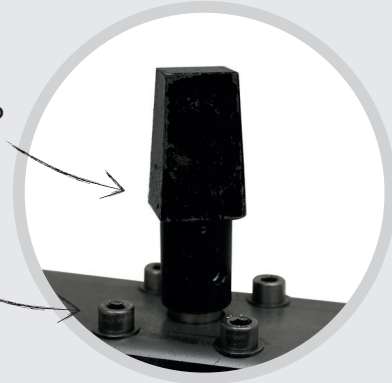

Back Side

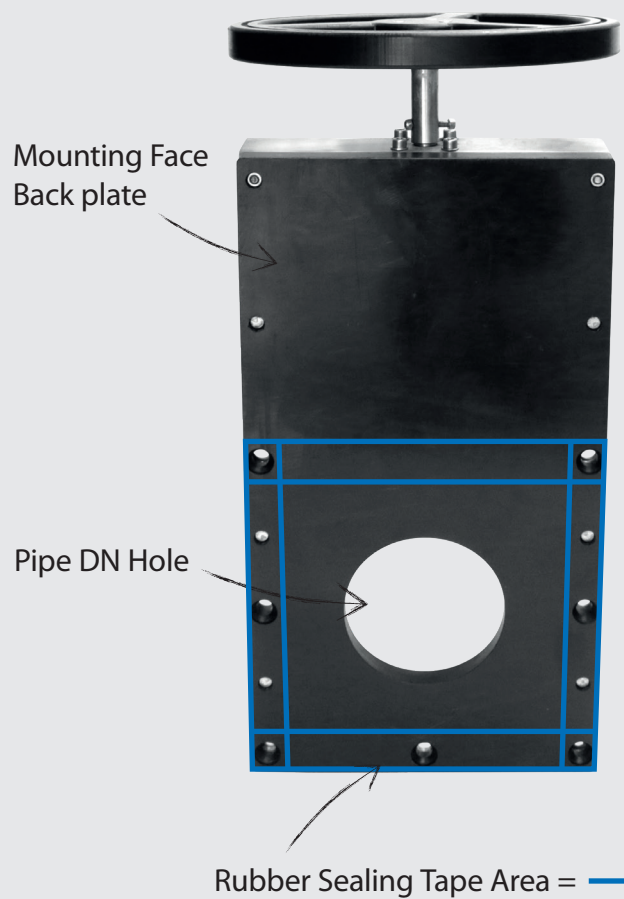

Construction Materials		
Component	Standard materials	Options
Frame	Grade 316 stainless steel (1.4401)	
Door plate	HDPE 500	
Backing plate	HDPE 300	
Reinforcements	Grade 316 stainless steel (1.4401)	
Non-rising spindle	Grade 316 stainless steel (1.4401) TR25 x 7.5	
Spindle bearing	PTFE	
Door nut	POM (self lubricating)	Bronze
Bolts & nuts	Grade 316 stainless steel (1.4401)	
Integrated Seal	EPDM	
On and off seating pressure	6m	

Standard Series Product Range

Product Code	Diameter (Ø)	A (mm)	B (mm)	C (mm)	D (mm)	E (mm)	F (mm)	G (mm)	H (mm)	Pressure (mwc)	Weight (kg)	Mounting Set
PS100	100	242	437	70	35.4	44.5	100	96	16	6	10.9	PSMS-01
PS150	150	294	537	70	35.5	44.5	100	96	16	6	14.3	PSMS-01
PS200	200	342	637	70	35.4	44.5	100	96	16	6	17.6	PSMS-01
PS250	250	394	737	70	35.5	44.5	100	96	16	6	22	PSMS-01
PS300	300	442	837	70	35.4	44.5	100	96	16	6	26.8	PSMS-01

Product Code	Diameter (Ø)	A (mm)	B (mm)	C (mm)	D (mm)	E (mm)	F (mm)	G (mm)	H (mm)	Pressure (mwc)	Weight (kg)	Mounting Set
PS400	400	622	1080	117	55	44	138	132	16	6	54.4	PSMS-02
PS450	450	670	1180	116	53	44	138	132	16	6	65.5	PSMS-02
PS500	500	718	1280	115	52	44	138	132	16	6	72.3	PSMS-02
PS600	600	820	1480	116	53	44	138	132	16	6	91.7	PSMS-02

 Larger sizes available on request

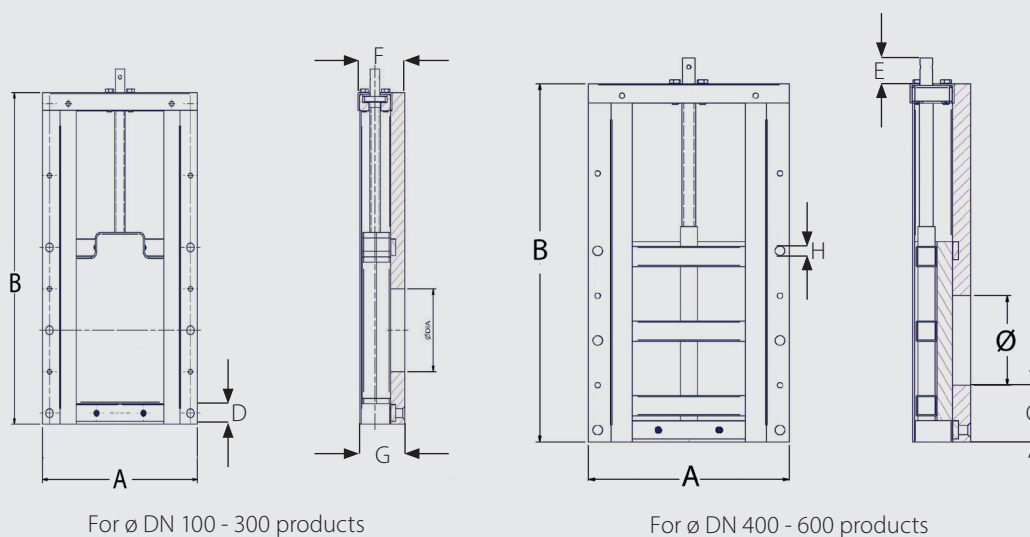



Accessories & Installation

Additional Component Parts		
Product Code	Description	Product Weight (kg)
PSTK	Penstock Tee Key (1090mm long)	3.5
PSGB	Penstock Guide Bracket	0.53
PSHW	Penstock Handwheel	1.52
PSES500	Telescopic Extension Spindle 500-750mm	1.24
PSES750	Telescopic Extension Spindle 750-1000mm	1.62
PSES1000	Telescopic Extension Spindle 1000-1500mm	2.27
PSES1500	Telescopic Extension Spindle 1500-2000mm	3
PSES2000	Telescopic Extension Spindle 2000-2500mm	3.64
PSES2500	Telescopic Extension Spindle 2500-3000mm	4.1
PSES3000	Telescopic Extension Spindle 3000-3500mm	5.02
PSES3500	Telescopic Extension Spindle 3500-4000mm	6.05
PSES4000	Telescopic Extension Spindle 4000-4500mm	7.28

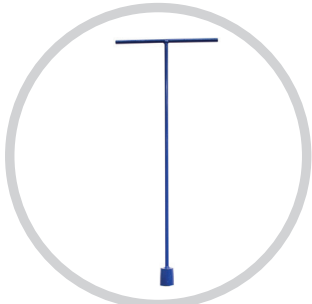

Tee Key



Penstock Guide bracket

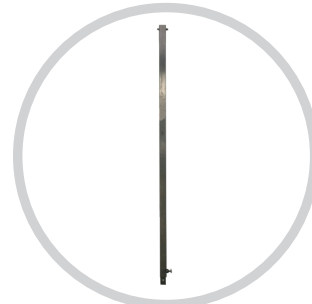

Extension Spindle



Hand Wheel

Introduction

The Fernco HDPE penstock is constructed using HDPE and Grade 316 stainless steel (1.4401).

The penstock has a vertically moving door manufactured in HDPE with stainless steel supports. The door incorporates an EPDM rubber lip seal to provide a seal against the back plate and is guided within a stainless steel frame with HDPE guides.

A rubber sealing tape is secured between the frame and the mounting wall, which is compressed during installation to provide a seal.

Handling

The HDPE Penstock should only be transported when laid flat with the door plate facing upwards. It can then be lifted by means of suitable equipment.

Where chains or slings are used for handling purposes, the frame should be protected using cloth sacking or similar material.

Fully trained personnel should carry out all necessary lifting.

Storage

It is recommended to store the penstock laid down flat with the door plate facing upwards, free of dust, dirt and moisture.

Mounting Set:

- 1) Rubber sealing tape (5mm thick)
- 2) Chemical anchor capsules
- 3) Fixtures and accessories

Penstock Installation Sequence

Before commencing installation, check that the civil work is correct to all appropriate drawings and that there are no obvious obstructions or undulations on the mounting wall. The performance of the sealing tape will be affected if the civil structure is not flat.

It is recommended that the mounting set is purchased with the penstock for ease of installation.

Tools Required

- Appropriate PPE
- Utility Knife
- Marker Pen
- Suitable Drill
- 14mm Drill Bit
- 15mm Drill Bit
- Torque Wrench
- 19mm Socket Set
- 8mm Socket Hex Key
- Hammer

1. Marking the Mounting Face

1. With suitable lifting equipment, lift the penstock and adjust it to ensure it is vertical and level.
2. Lower the penstock into the required aperture.
3. Check and adjust the penstock into the correct position, ensuring the invert of the pipe is flush with the invert of the penstock opening.
4. Mark all of the mounting holes.
5. Penstocks DN400 and over have additional mounting holes above the penstock opening. These are accessed by fully closing the penstock. Specific Drop In Anchors are supplied in the mounting kits for these sizes and are installed using an anchor setting tool that is available for purchase separately (T-M12PUNCH).
6. Remove the penstock.

2. Procedure for installing Chemical Anchor Attachments

Standard Chemical Anchors Set comprising of:

- Stainless Steel M12 Threaded Stud
- Chemical Anchor Capsules
- Stainless Steel Nuts and Washers

1. Using a 14mm drill bit, drill the mounting holes to a depth of 110mm in their required positions.
 - 1a) **DN400 and above** – Drop In Anchor Installation
For the mounting holes above the door, using a 15mm drill bit, drill the holes to a depth of 55mm.
2. Blow out the drilled holes using compressed air.
(Warning: Suitable eye protection to be worn)
3. Insert a chemical anchor capsule into each hole.
 - 3a) **DN400 and above** – Drop In Anchor Installation
Place the anchor inside the hole. Drive the anchor setting tool (or an equivalent device) into the anchor with a hammer, until flush with the anchor base.
4. Attach the M12 stud to a suitable drill.
5. Place the end of the stud into the hole, then in one motion operate the drill at high speed, and push the stud through the chemical anchor to the back of the hole. Once the back of the hole is reached, stop the drill to prevent resin escape.
6. Carefully remove the drill from the stud. Take care not to move the stud.
7. During the curing time, move on to section 3 (see table 2 for cure times).

Mounting Kit	Number of Bolts	Bolt Size	Drill Bit Required	Drill Depth	Tightening Torque
PSMS-01	7	M12	14mm	110mm	25Nm
PSMS-02	10	M12	14mm	110mm	25Nm

Table 1 – Mounting kit installation data

Temp °C	-15 to -10	-9 to -5	-4 to 0	1 to 5	6 to 10	11 to 20	21 to 30	31 to 40
Cure Time	30h	16h	10h	45min	30min	20min	5min	3min

Table 2 – Curing time data

3. Placing the Rubber Sealing Tape

1. Ensure that the penstock back plate is clean and smooth.
2. The sealing tape has adhesive on one side with a protective layer over it. Cut the tape larger than necessary, then remove the protective layer and fit it onto the frame.
3. The tape should now be cut to length and squared so that the corners connect properly.
4. Drill holes through the tape by using the mounting holes in the penstock as a guide.

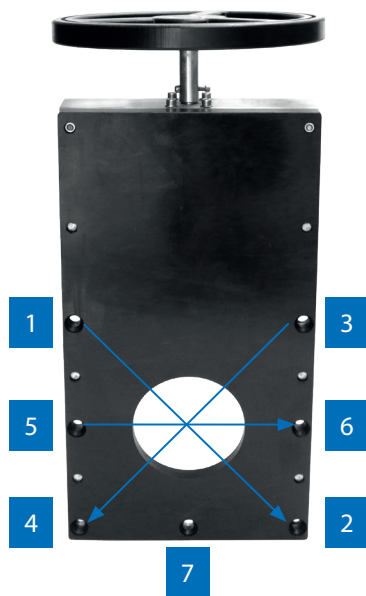

4. Final Steps

1. Place the penstock over the studs, then place a washer and a nut onto each stud and tighten by hand.

If applicable, screw the corresponding threaded bolts into the anchors by hand.
2. Once all washers and nuts have been placed, proceed to tighten the nuts evenly to the recommended torque. If applicable, also tighten the threaded bolts into the anchors.

It is recommended that all fixtures are tightened following the number pattern illustrated in the image (25Nm with a Fernco Mounting Set)*. The sealing tape must be compressed evenly to ensure a good seal, however, the frame must not be allowed to deform.

**For Penstocks DN400+ there are additional anchor mounting holes. Tighten these within the number pattern, ensuring opposite mounting holes are selected when choosing the next hole.*

Installation Of An Extension Spindle

1. Remove the BS Cap.
2. Place the extension spindle over the spindle of the penstock.
3. Place the upper bracket 150mm below the deck or the top of the spindle extension. Divide the other brackets over the length of the spindle extension (one additional bracket for every 3m).
4. Mark the mounting holes of the bracket(s) in such a way that the extension spindle is in the required position.
5. Remove the extension spindle.
6. Install the brackets as required.
7. Reinstall the extension spindle; adjust the position of the brackets if necessary to ensure the proper alignment of the spindle extension.

Post-Installation Checks

To ensure effective operation, the following checks are recommended before leaving the installation site:

- a. Condition of the frame – This can be distorted during the installation process if due care is not taken.
- b. Debris between the door and the frame at the invert – Remove all debris to ensure effective seal performance.
- c. Seal and Sealing Tape condition – Check the seal and tape for any damage.
- d. Fixtures – Tighten all fixtures where necessary.
- e. Misalignment of the extension spindle.

Note: DO NOT use excessive force when opening or closing a penstock door, as damage could occur.

Maintenance Recommendations Hdpe Penstocks

The penstock should give up to 100 year life expectancy with regular inspection and appropriate maintenance.

1. The following parts require attention in particular and need to be cleaned if necessary
 - o Spindle block (dirt and wear)
 - o Spindle (dirt and wear)
 - o Spindle stop (present)
 - o Seals (dirt and wear)
2. Check for leakage between the frame and the mounting wall. If leakage has occurred, first follow the remaining inspection steps. If all fixtures are now tight, the unit is clean and there is no obvious damage to any components, schedule another inspection to see if leakage continues.
3. Clean the unit by hosing it down to remove any grit or debris.
4. Check the tightness of the bolts and nuts.
5. Check there is no damage to the frame, door or seals.
6. Check the operating equipment for damage and freedom of movement, and ensure that there are no damaged or worn parts.
7. When carrying out any maintenance work with the penstock door in the open position, always ensure that the door is securely and independently supported.

Frequency of Inspection:

The inspection frequency should be based on the particular installation requirements. In an aggressive environment or in locations with large amounts of silt or debris, it is strongly recommended to increase the inspection/maintenance interval.

General Information

Quality, Standards and Approvals

Certified by the British Standards Institution (BSI) as a company of assessed capability, with a quality management system which meets the requirements of BS EN ISO 9001:2015

Fernco are the leaders in wastewater connection innovation; utilising the most advanced methods and techniques for precision-manufactured products, all of which comply with or exceed relevant British and European standards to ensure reliability and sustainability.

Environment

Operating Environmental Management Systems which are certified to ISO 14001: 2015.

Supply

All Fernco products are supplied through a national and global network of distribution and merchant partners. For stockist details, contact Fernco.

Technical and Sales Support

P&I have a team of product experts on hand to support all customers with technical support and advice.

Contact P&I Technical Department:

Tel: +64 (09) 448 5844

Email: orders@pandi.co.nz