

Hydroclass® Zinalium® Ductile Iron Pipe

The perfect ductile iron pipe for robust and flexible water distribution networks in all situations

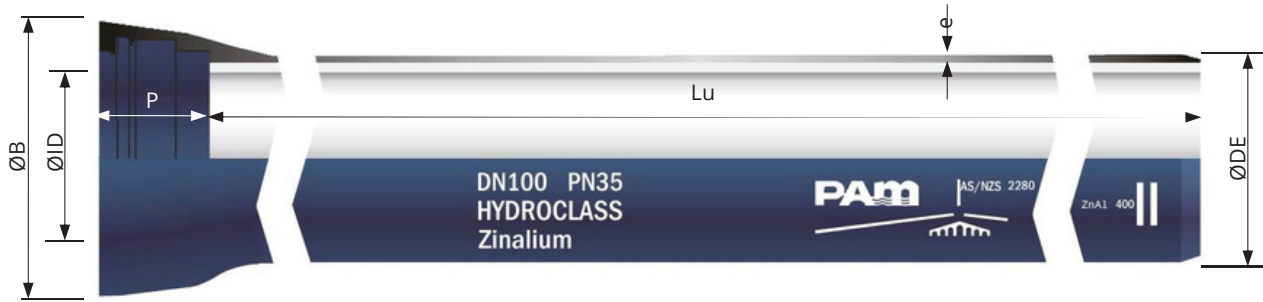

AS/NZS 2280 HYDROCLASS ZINALIUM® Pipe with TYTON® TYPE Joint
DN100-750 PN35

Features

Withstands high service pressures and external mechanical accidents, and is impervious to pollution in soil, ensuring water tightness.

Designed for all terrains, climates and situations.

No need for any welding, coating repair, or ultrasonic exam, nor specialised equipment or waiting time for the drying or cooling of assemblies

Designed with a safety reserve that securely withstands increases in flow, pressure, and surface loads of roads and buildings.

Main characteristics

AS TYT joint in EPDM (preferably supplied by Hultec) to AS1646

External coating: ZINALIUM® alloy Zn85Al15 (400 g/m²)

Blue cobalt synthetic pore sealer minimum 100 microns to AS3750.19

Internal coating: Blast Furnace Slag Cement mortar (BFSC) to AS3972 type GB

If required can seal coated with Endolac 245.10 to ISO 16132 In conformance to AS/NZS 2280:2014

Water contact areas tested to AS/NZS 4020

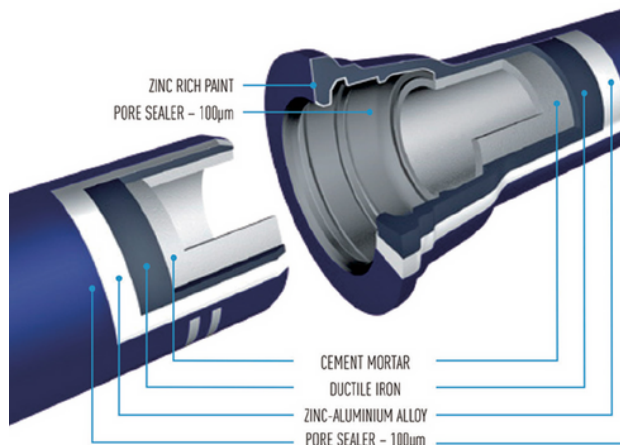

Field of use

For drinking water networks and raw and recycled water

Pressure Watermain

Product Code	DN (mm)	Lu (m)	PN	e (mm)	ØDE (mm)	ØID (mm)	P (mm)	ØB (mm)	Mass (kg/m)
DIP35100ZN	100	5.75	PN35	4.9	122	124.7	89	162.7	17.5
DIP35150ZN	150	5.75	PN35	5.0	177	179.7	89	218.3	26.1
DIP35200ZN	200	5.75	PN35	5.0	232	235.2	102	278.2	34.8
DIP35225ZN	225	5.75	PN35	5.0	259	262.1	102	303.4	39.2
DIP35250ZN	250	5.75	PN35	5.2	286	289.0	102	329.5	44.6
DIP35300ZN	300	5.75	PN35	5.9	345	348.2	102	391.4	59.0
DIP35375ZN	375	5.75	PN35	7.0	426	430.5	127	487.3	84.4
DIP35450ZN	450	5.75	PN35	8.1	507	511.2	127	570.7	112.7
DIP35500ZN	500	5.75	PN35	8.8	560	564.3	127	626.0	133.0
DIP35600ZN	600	5.75	PN35	10.2	667	671.2	135	751.4	178.9
DIP35750ZN	750	5.75	PN35	12.3	826	830.2	157	912.7	268.2

Note: Dimensions and mass are given as nominal value Higher pressure is available for Flange Class

Legend

DN : nominal diameter

Lu : laying length, in m

PN : pressure rating according to AS/NZS 2280:2014

e: nominal thickness according to AS/NZS 2280:2014, in mm

ØDE : external nominal diameter of the barrel according to AS/NZS 2280:2014, in mm

ØDI : internal nominal diameter of the socket, in mm

P : nominal depth of the socket, in mm

ØB : nominal external diameter of the socket, in mm

Mass : mean total mass per meter

Available Diameter Range	DN100, 150, 200, 225, 250, 300, 375, 450, 500, 600, 750
Pressure Rating	PN20 – Green mark on socket face PN35 – Red mark on socket face Flange Class – Blue mark on socket face
Joints	Automatic push in Tyton type rubber ring joint - DN100 to 600
Deflection	DN100-250: 3.5° DN300-750: 1°
External Coating	ZINALIUM® alloy Zn85Al15 (400 g/m ²) with a Blue cobalt synthetic pore sealer top coat. Ductile iron pipes with ZINALIUM® can be buried in direct contact with soil (No LPS) except in the following situations: <ul style="list-style-type: none"> • Soils with a resistivity lower than 500 Ω.cm • Peaty and acid soils • Soils containing acidic industrial effluents, ashes or slag
Internal Coating	Blast Furnace Cement Mortar (BFSC)
Length	DN100 to DN750: L=5.75m