

HYDRANTS

SAINT GOBAIN BS750 SQUAT FIRE HYDRANT

- DN80 PN16
- Fully compliant to BS750, EN14339, EN1074-6
- Maximum operating temperature 60 °C
- Flange conform to AS 2129 Table D slotted 80/90mm
- Stainless steel outlet Conform to BS 336
- Operating cap top 35 x 35mm
- Close direction CC (clockwise)
- MOT: 105N.m



FH2 80 BS750 Underground Fire Hydrant Squatt c/w frost plug

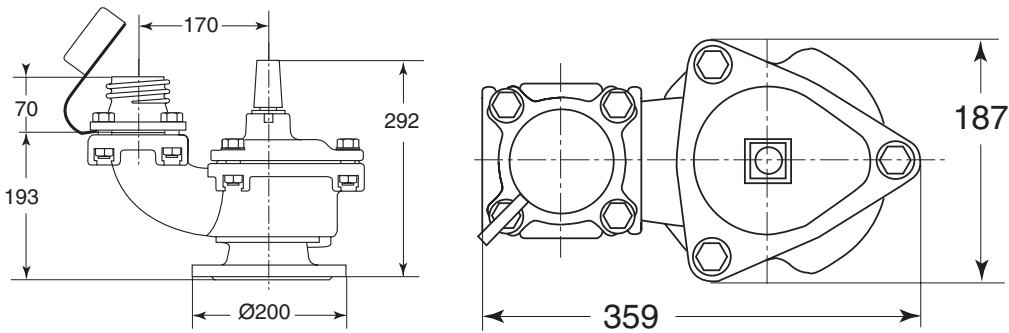

Diameter	Flange Dimension			Outlet Dimension
	PCD	Hole Size	Hole Quantity	
80mm	146mm-165mm	80/90mm	4	Conforms to BS 336